

DESCRIPTION

Don Alarm Standard Alert (DA10) is a plumbing safety device that continuously monitors system water pressure and provides an alert (audible beep) when excessive pressure occurs.

FEATURES

- 24/7 Continuous pressure monitoring
- Detects harmful & dangerous water pressure
- Audible alert when pressure exceeds 80 psi
- Standard plumbing connection (3/8" compression thread)
- 12 Hour Sleep Mode
- Low battery indicator and test mode
- Easy installation, connect & go
- No monthly fees
- Patented technology

OPERATING SPECIFICATIONS

Alarm Trigger Pressure	80 +/- 5 psi
Alarm Reset Pressure	75 +/- 5 psi
Maximum Pressure	150 psi
Operating Water Temperature Range	20 - 120 °F
Plumbing Connections	Compression (3/8" OD Tubing)
Power Source	2, AA Batteries
Unit Weight	Approx. 1 Lb.
Medium (fluid type)	Potable water

APPLICATIONS

- Potable water systems
- Residential water systems
- Light commercial water systems

INSTALLATION

Install Don Alarm in-doors, on a pressurized potable water system (cold water is recommended). Water must be free from particulates or contaminants that could damage the sensing element and void warranty. Mount in an upright position (as shown below) to prevent debris from obstructing internal components.

DIMENSIONS & COMPONENTS

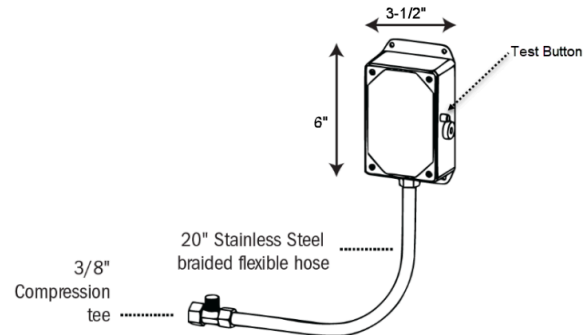

MAINTENANCE

All plumbing system components should be inspected at least once a year by a qualified plumbing professional. Press the red test button located on the side of the Don Alarm to check the battery. If the unit is normal, you will hear 2 short beeps. If the battery is low, Don Alarm will notify user by 3 quick beeps, once every minute until the batteries are replaced or completely depleted.



MODEL: DAK10

Product Data Sheet

Don Alarm Kit with Standard Alert

WARRANTY

Don Alarm Standard is covered by a 2 year limited warranty. This warranty covers defects in materials and workmanship under normal use and service. If the product fails to function as intended due to a manufacturing defect, we will repair or replace it free of charge. This warranty does not cover damage caused by misuse, abuse, accidents, modifications or improper installation. Don Alarm Company liability is limited to products manufactured by us and excludes all property or other damage. To submit a warranty claim, please contact our customer service team and provide proof of purchase. Our team will guide you through the process and ensure that your issue is resolved as quickly and efficiently as possible.

CONTACT US

We are here to help. If you need technical assistance, support, or just have a question, please reach out to us by phone, email, via our website or mailing address as listed below. We appreciate your business and look forward to hearing from you.

Web: www.DonAlarmCo.com

Email: Contact@DonAlarmCo.com

Phone: 866.240.8233

Don Alarm Company, Inc.
771 Jamacha Road, #325
El Cajon, CA 92019